

Brandon Township

Douglas County, Minnesota

Mailboxes and Support System

Brandon Township is looking to upgrade the present mail box support system along its township roads in order to better enable effective snow plowing and grading of its roads. The new system will also be safer for traffic and will result in less mail box damage. A mailbox support system similar to that adopted by the Douglas County Highway department (SwingSAFE Support System) is the desired option.

Brandon Township residents are required to install the new swing safe type system whenever they replace their current mail box posts or if the town board deems the existing mailbox support a hazard. The township will reimburse the resident 50% of the cost of a SwingSAFE post upon a receipt from the resident. This does not include installation of the new post or mail box.

All newly built township roads taken over by Brandon Township will require the new system to be installed by the developer of the new road. Any township roads to be rebuilt or paved by Brandon Township will also require the new support system.

If damage is done by a township snowplow or grader to a mailbox that has a swing away post, the township will be responsible for the cost of replacing the mailbox (up to a maximum of \$30) upon receipt from the resident. There will be no reimbursement for non-swing away posts or for mailboxes not on a SwingSAFE post.

The SwingSAFE post are available at most stores that sell mailboxes.

Adopted June 15, 2020

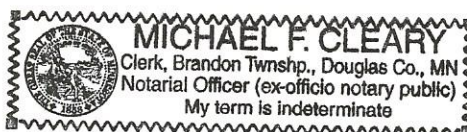

Clerk, Mike Cleary

Chairman, Kerby Lund

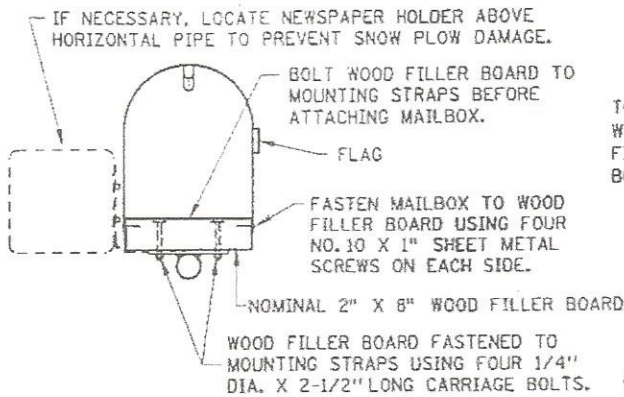

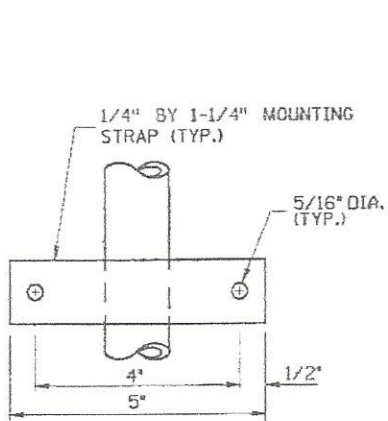

SECTION A-A



TOP VIEW



END VIEW

MOUNTING STRAP DETAIL

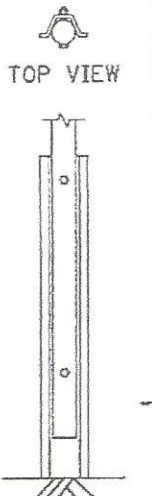

ROADWAY VIEW
PIPE/POST
CONNECTION

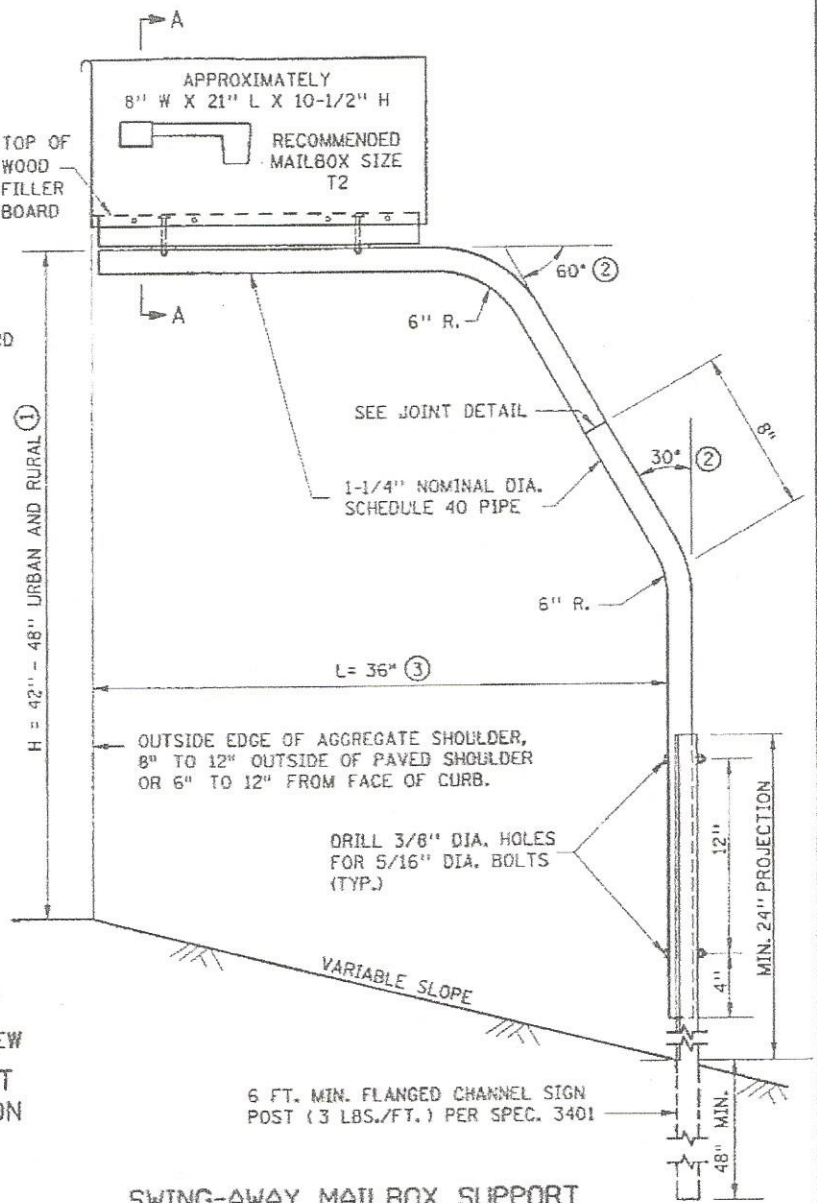

SWING-AWAY MAILBOX SUPPORT

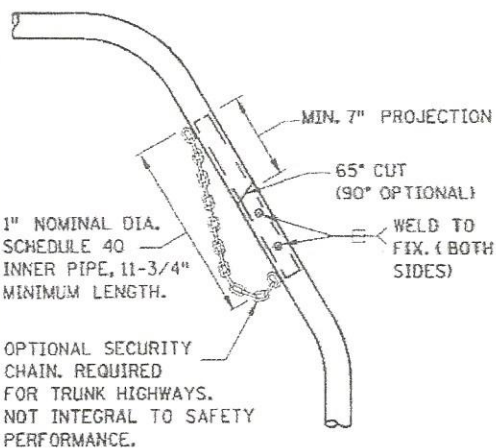

JOINT DETAIL

NOTES:

MAILBOX LOCATIONS SHOULD BE STAKED BEFORE INSTALLATION FOR PROPER HEIGHT AND DISTANCE FROM THE ROADWAY. ONCE STAKED, THE INSTALLER MUST NOTIFY THE ENGINEER AND THE POST OFFICE. THE ENGINEER AND THE POSTMASTER SHALL APPROVE THE STAKED LOCATIONS PRIOR TO FINAL INSTALLATION.

THE MINIMUM SPACING (CENTER TO CENTER) BETWEEN MULTIPLE MAILBOX SUPPORTS SHALL BE EQUAL TO THE HEIGHT OF THE MAILBOX SUPPORT.

OTHER MAILBOX SUPPORT DESIGNS MAY BE USED IF THEY SATISFY NCHRP REPORT 350 CRITERIA IN ACCORDANCE WITH FHWA ACCEPTANCE LETTER, MEET MINNESOTA RULES 8818 AND U.S. POST OFFICE RECOMMENDATIONS AND ARE IN COMPLIANCE WITH MN/DOT REQUIREMENTS WHICH MAY INCLUDE THE FOLLOWING (REQUIRED ON TRUNK HIGHWAYS):

PIPE SHALL CONFORM TO SPEC. 3362, SCHEDULE 40 OF ASTM A53/A53M.

ALL FASTENERS SHALL CONFORM TO SPEC. 3391.

PIPES, POST AND OTHER STEEL COMPONENTS SHALL BE GALVANIZED PER SPEC. 3392.

THE CONTRACTOR SHALL SEND THE SHOP DRAWINGS TO THE ENGINEER FOR APPROVAL. FOR QUESTIONS REGARDING DESIGN ELEMENTS AND BREAKAWAY FEATURES, CONTACT THE DESIGN STANDARDS UNIT.

① ANY CHANGE IN HEIGHT (H) MUST BE APPROVED BY LOCAL POSTMASTER.

② 45° BENDS MAY BE USED AS AN OPTION.

③ A 48" OR 53" CANTILEVER LENGTH (L) MAY BE USED AS AN OPTION FOR NON-TRUNK HIGHWAY USE.

APPROVED JUNE 1, 2007

Milakus

STATE DESIGN ENGINEER

STATE OF MINNESOTA
DEPARTMENT OF TRANSPORTATION

MAILBOX SUPPORT
SWING-AWAY TYPE

SPECIFICATION
REFERENCE

3362
3391
3392
3401

STANDARD
PLATE
NO.

9350A